

TE0009616A OLED Graphic 96x16 dots

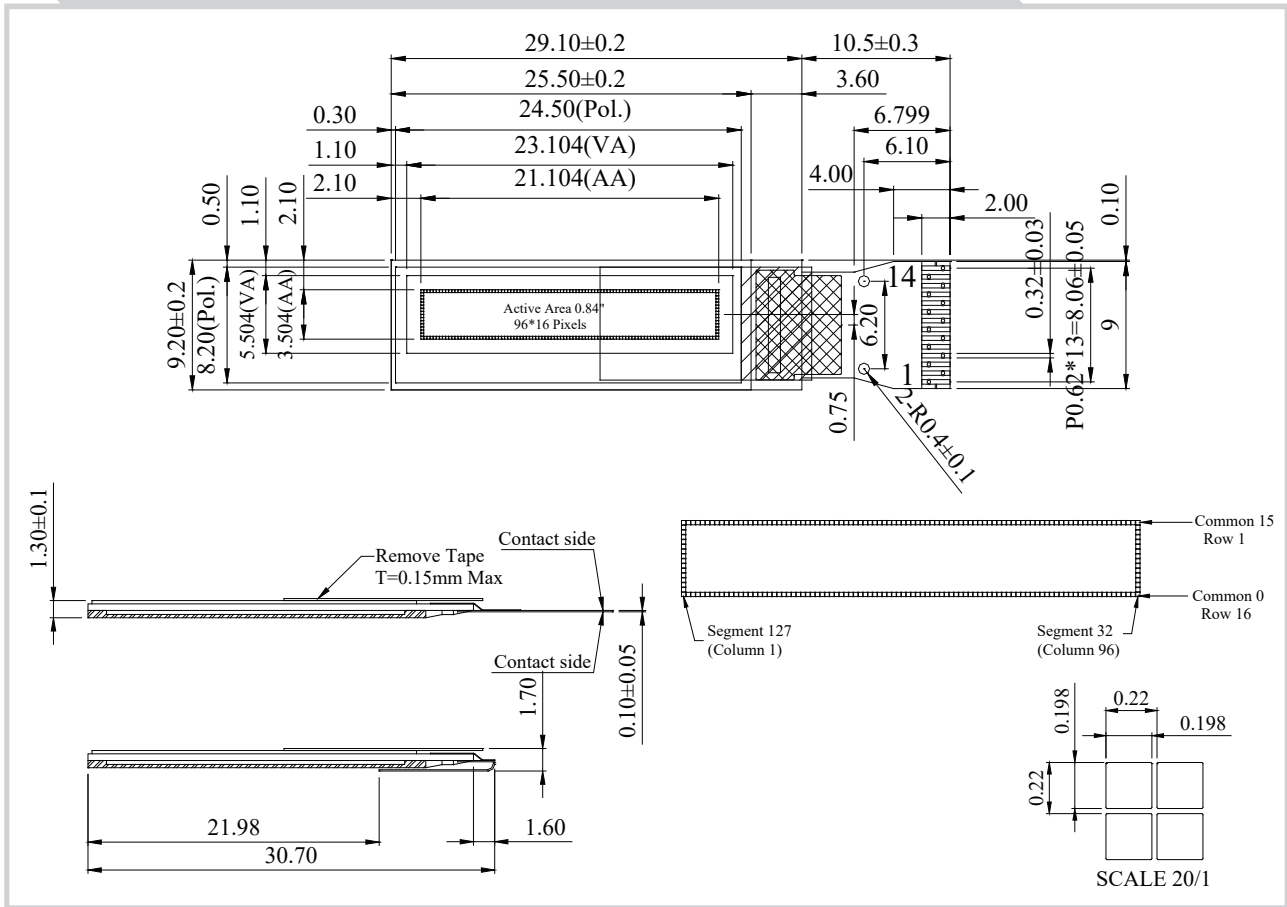

Feature

1. 96*16 Dot Matrix
2. Built-in controller SSD1306BZ
3. +3V Power supply
4. 1/16 duty
5. Interface: I2C
6. Polarizer optional

Pin No.	Symbol	Description
1	C2N	Charge pump capacitor
2	C2P	Charge pump capacitor
3	C1P	Charge pump capacitor
4	C1N	Charge pump capacitor
5	VBAT	Charge pump regulator
6	NC	No Connection
7	VSS	Ground Pin
8	VDD	Voltage for logic
9	RES#	Reset Signal Pin
10	SCL	Serial clock
11	SDA	Serial data
12	IREF	SEG Current Refer Pin
13	VCOMH	COM deselected level
14	VCC	Panel driving voltage

Mechanical Data

Item	Standard Value	Unit
Module Dimension	29.10 x 9.20	mm
Viewing Area	23.104 x 5.504	mm
Active Area	21.104 x 3.504	mm
Dot Pitch	0.22 x 0.22	mm
Dot Size	0.198 x 0.198	mm

Electrical Characteristics

Item	Symbol	Condition	Standard Value			Unit
			min.	typ.	max.	
Input Voltage	VDD	---	2.8	3.0	3.3	V

大成通商株式会社

〒105-0004
東京都港区新橋2-19-2リプロ新橋6階
info@taiseitsusho.co.jp